

The Sony EVI-D100 (NTSC) and EVI-D100P (PAL) video cameras are a great choice for any application that requires a high-quality color video camera with the flexibility of remote pan/tilt/zoom operation, all in a compact easy-to-use package. These high quality CCD cameras combine a high-speed, quiet pan/tilt with a wide angle of view and 40x zoom. Auto focus and automatic exposure control with back light compensation are fast and stable and can easily cope with difficult lighting conditions. The EVI-D100/P models are ideal for applications such as videoconferencing, distance learning and corporate training, surveillance, telemedicine, sports, concerts and internet communications such as webcasting. Additional advantages are provided by easy to use presets, daisy-chaining capability and various digital picture effects.

EVI-D100 EVI-D100P



Component/OEM

FEATURES

- **High Speed, Wide Range Pan/Tilt**

The camera moves to a designated position quickly and immediately with one of the highest pan/tilt speeds in its class.
Max. Pan speed: 300 degrees/s (range \pm 100 degrees)
Max. Tilt speed: 125 degrees/s (range \pm 25 degrees)

- **Quiet Operation**

Direct drive motors account for the gearless structure of the camera, reducing the noise of pan/tilt motion drastically compared to conventional models.

- **40x Zoom Ratio (10x Optical + 4x Digital)**

The fast and stable auto focus zoom lens reaches an impressive 40x zoom ratio.

- **Built-in Conversion Lens for Wide Angle View (65 degrees)**

The EVI-D100/D100P incorporates a newly developed wide-angle lens for wide field of view image capturing, making it ideal for use in small-sized rooms.

- **Six Position Presets with Battery Back-up**

An integral back-up battery stores presets of pan/tilt/zoom, focus position, AE mode and White balance mode, even when the unit is powered off.

- **Auto Sleep Function**

The camera can be set to automatically turn off when not in use after a specified period of time.

- **Various Picture Effects**

Mirror Image, Still Image on Field Memory, Pastel Image, Negative/Positive Reversal, Enhanced Contrast, etc.

- **Multi-function IR Remote Commander® unit**

Easy-to-use supplied remote commander unit is useful for basic pan/tilt/zoom camera control.

- **RS-232C Serial Control by VISCA™**

Control all camera settings and pan/tilt/zoom functions remotely via PC.

this is not a rehearsal.

www.sony-vision.com

SONY

SPECIFICATIONS

	EVI-D100	EVI-D100P
Video Signal	NTSC	PAL
Image Sensor	1/4 type Super HAD CCD	
Effective Pixels	768 (H) x 494 (V)	752 (H) x 582 (V)
Horizontal Resolution	470 TV lines (Wide end)	460 TV lines (Wide end)
Lens	x10 Optical Zoom, x40 with Digital Zoom, f = 3.1 to 31, F 1.8 to 2.9	
Horizontal Angle of View	6.6 to 65 degrees	
Minimum Object Distance	100 mm (Wide end), 600 mm (Tele end)	
Minimum Illumination	3.5 lx (F1.8)	
Auto Exposure	Auto/Manual/Priority AE, Exposure compensation, Back light Compensation	
Shutter Speed	1/4 to 1/10,000 S	1/3 to 1/10,000 S
White Balance	Auto, ATW, Manual, One Push, 3200K, 5800K	
Effects	Mirror Image, Still Image on Field Memory, Pastel Image, Negative/Positive Reversal, Sepia Image, Monochrome Image, Enhanced Contrast, Mosaic Image, Vertical Stretch, Horizontal Stretch, Motion Image on Still Image, Continuous Still Image, Motion Images on Binaried Still Image, After-image Lag of Moving Object	
S/N Ratio	More than 50 dB	
Pan/Tilt	Horizontal \pm 100 degrees (Max speed 300 degrees/s), Vertical \pm 25 degrees (Max speed 125 degrees/s) (in 0.07 degrees increments)	
Video Output	VBS, Y/C	
Power Requirements	DC 10.8 to 13.0 V	
Power Consumption	Max. 13.2 W (at 12 Vdc)	
Operating Temperature	0 to 40 °C (32 to 40 °F)	
Storage Temperature	-20 to 60 °C (-4 to 140 °F)	
Dimensions	113 (W) x 120 (H) x 132 (D) mm (4 1/2 x 4 3/4 x 5 1/4 inches)	
Weight	860 g (1 lb 14 oz)	
Supplied Accessories	AC Adaptor (x1), IR Remote Commander unit (x1), Velcro tape (x1), Operating Instructions (x1)	

DIMENSIONS

Unit: mm

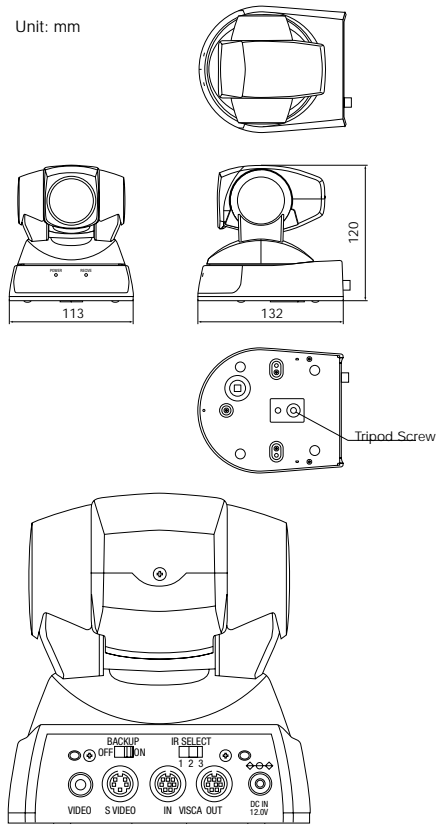

PAN/TILT RANGE

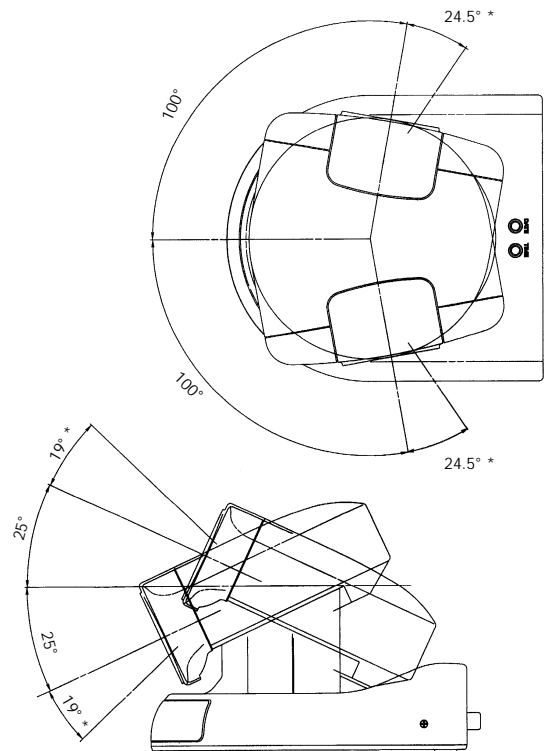

*Angle of view

Product information is available on the Sony Home Page

Click!

<http://www.sony-vision.com>

Sony Belgium (ICS) +32 2 724 18 24
 Sony France (ICS) +33 1 55 90 41 58
 Sony Germany (ICS) +49 221 537 8923
 Sony Italy (ICS) +39 02 61 83 84 06
 Sony Netherlands (ICS) +31 20 658 1502
 Sony Nordic (ICS) +46 40 19 08 06
 Sony Spain (ICS) +34 902 41 51 61
 Sony UK (ICS) +44 1932 816 340

© 2001 Sony Corporation. All rights reserved.
 Reproduction in whole or in part without written permission is prohibited.
 Design and specifications are subject to change without notice.

PDF EVI-D100/100P/GB-28/08/2001

SONY