

Panasonic
ideas for life

PT-LB60/LB55 Series

Micro Portable Wireless XGA LCD Projectors

PT-LB60NTEA **3200 lm XGA**

PT-LB55NTEA **2500 lm XGA**

Micro Portable XGA LCD Projectors

PT-LB60EA **3200 lm XGA**

PT-LB55EA **2500 lm XGA**



The World's Fastest Wireless Transmission Projectors



- Easy wireless projection (PT-LB60NTEA/LB55NTEA)
 - World's fastest data transfer*¹
 - Wireless PC motion/sound streaming*²
 - Abundant wireless functions, including wireless prompter and 16-window index style
 - Simple, user-friendly settings
- Daylight View 2 technology
 - Looks max. 50% brighter*³
 - Vivid colours in a bright room
 - Auto operation with ambient light sensor (ALS)
- High power and portability
 - Bright 3,200/2,500 lumens*⁴
 - Ultra-lightweight: 2.6 kg (5.7 lbs)*⁵
 - Slim and compact design: 83-mm (3-1/4") thickness*⁶
- Quick operation
 - 2-second speed start
 - Auto search
 - Real-time keystone correction
 - Operation assistance
 - Direct power off

*¹ As of February 7, 2006, according to our own evaluation of wireless transmission from PC to projector. Wireless projection function is featured on the PT-LB60NTEA and LB55NTEA only.

*² Content and DVDs set with DRM (Digital Rights Management) cannot be transmitted.

*³ Comparison with Daylight View 2 turned On and Off, using an 80-inch screen and ordinary meeting room lighting of 400 lux. (Projector: PT-LB60NTEA, screen gain: 2.6)

*⁴ 3,200 lumens for the PT-LB60NTEA and PT-LB60EA; 2,500 lumens for the PT-LB55NTEA and PT-LB55EA.

*⁵ 2.5 kg/5.5 lbs for the PT-LB60EA and PT-LB55EA; 2.6 kg/5.7 lbs for the PT-LB60NTEA and PT-LB55NTEA.

*⁶ Legs and protruding parts not included.

Simple & Flexible Wireless Projection

The presenter is over here.



Wireless Projector

The PT-LB60NTEA and PT-LB55NTEA feature a wireless LAN function. There are no cables to connect other than the power cord, so setup is quick and easy and you have full layout flexibility. Featuring a host of convenient wireless functions, Both projectors enhance the projection applications. In addition, the PT-LB60/LB55 series projectors incorporate Panasonic's original Daylight View 2 technology, which makes images easy to see even in brightly lit rooms.

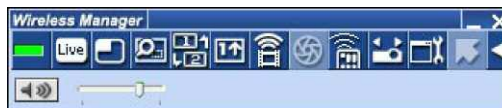

Wireless Manager Control Panel (Launcher)

Easy Wireless Projection (PT-LB60NTEA/LB55NTEA)

The World's Fastest Data Transfer**

Boasting wireless data transmission at five times the speed of our conventional model**2, the PT-LB60NTEA/LB55NTEA provides a smooth display of moving picture files**3 at 30 fps**4.



Moving picture

Sound



Wireless PC Motion/Sound Streaming
In addition to the moving pictures, audio data can be sent at the same time, so you can give Microsoft® PowerPoint® presentations rich in moving pictures and sound effects with wireless convenience.

Abundant Wireless Functions
The PT-LB60NTEA/LB55NTEA provides a host of convenient wireless functions, including Wireless Prompter (Secondary Display Transmission), selective area transmission and 16-window index style that lets you project images from up to 16 PCs at the same time. Wireless transmission is possible from one PC to a maximum of eight projectors at a time.

Wireless transfer



High-Speed Data Transfer

In Live mode and Multi Live mode, the content of the PC screen is projected with the same smooth image motion as you get with a wired connection.

Set yourself free.!!!

Simple, User-Friendly Operation

The settings for wireless connection can be made quickly and easily using Wireless Manager ME 3.0 software, which installs easily onto a PC using the included CD-ROM. You can also copy Wireless Manager onto a memory card and take it to a presentation site. This gives you wireless projection even where there are no PCs with Wireless Manager ME 3.0**5. When the Wireless Manager ME 3.0 is finished, the PC's LAN settings are restored to their original state, so the PC is ready to reconnect to your company LAN.

Other Wireless Features

- Projector control/status monitoring capability via an Internet browser
- Automatic connection to registered projectors
- The security method complies with WPA-PSK and WPA2-PSK.
- The Advanced Encryption Standard (AES) is used for all communication encryption.
- Wireless shutter function
- One-shot mode
- PowerPoint® page up/down operation using the supplied remote control

A host of convenient wireless functions

Wireless Prompter Function (Secondary Display Transmission)



This allows transmission of content other than what's displayed on your PC. For example, you can display text documents on your PC screen while projecting slide from your Microsoft® PowerPoint® presentation**6. You get a host of other convenient wireless transmission functions too, such as area-specified transmission and a multi-live mode for simultaneous display of up to 16 PCs.

Selective Area Transmission



By using the area select window, you can specify the necessary information alone from the computer screen, and display it on the projection screen.

Multi-Live Mode

• Four-Window Style
The operation is controlled using Wireless Manager ME 3.0.

• Index Style: Four Thumbnails
This style projects images from up to four PCs as small windows along the bottom of the screen.

• Extended Index Style: 16 Thumbnails
This style projects images from up to 16 PCs as small windows. Using the projector's remote control, you can select any one of the index windows and display it on the main window or on a full screen.

Multiple Source Live Mode

You can simultaneously project a single computer's screen on up to eight projectors. This mode is useful when a number of projectors are installed, for example, in a large conference room, or when holding simultaneous presentations in several conference rooms.



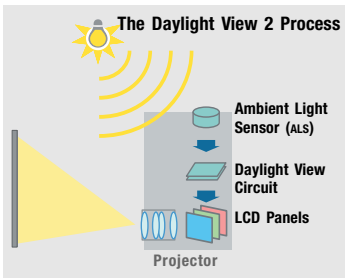

Daylight View 2



Looks max. 50% brighter

Panasonic's Daylight View 2 technology, which helps project sharp, crisp images that are easy to see even in brightly lit rooms. A built-in sensor measures the ambient light, and the halftone colours and brightness level are adjusted accordingly in real-time. Viewing brightness is increased by as much as 50%*7.



Simulated image when the Daylight View 2 is turned on.

Simulated image when the Daylight View 2 is turned off.

High Power and Portability

Ultra-High Brightness

Thanks to a high-performance optical system and high-efficiency 220-W UHM™ lamp, the PT-LB60NTE and PT-LB60EA deliver an ultra-bright 3,200 lumens and the PT-LB55NTEA and PT-LB55EA offer 2,500 lumens. Sharp, crisp images are easy to see.

Ultra-Lightweight and Compact

The PT-LB60NTEA/LB55NTEA at only 2.6 kg and the PT-LB60EA/LB55EA at 2.5 kg each pack a wealth of advanced Panasonic technology into a compact body—327 mm wide by 233 mm deep and only 83 mm high.

Quick Operation

Two-Second Speed Start

With Speed Start, the image appears in about two seconds after you press the power button.

Auto Search

When a source is connected and you switch the unit on, it automatically detects what kind of source is connected and begins projection.

Real-Time Keystone Correction

The projector automatically senses if you adjust its angle (vertical direction) during operation and instantly makes whatever keystone correction is necessary for optimum viewing.

Direct Power Off

You can disconnect the power cable and move the projector as soon as your presentation is finished, because the cooling fan keeps operating until the lamp is cooled. For fixed installation systems, this means you can turn off the room's main power without waiting for the projector to cool down.



Other Features

- Operation assistance
- Short-throw zoom lens
- Anti-theft features: User password, control panel lock and text superimposing
- Projector AI
- Index Window
- Auto power off
- Two RGB inputs

- RGB 2 IN can be switched to RGB 1 OUT for loop-through monitoring
- HDTV compatibility
- Full compatibility with sRGB colour space for accurate colour reproduction (in natural mode)
- Picture mode selection (standard/dynamic/natural)
- Blackboard mode allows you to project images onto an ordinary classroom or conference room blackboard
- 3x digital zoom
- Shutter function for image/sound muting
- Selectable 17-language on-screen menu
- Ceiling mountable (option)

Optional ceiling mount bracket: ET-PKB30



Remote control for the PT-LB60NTEA and PT-LB55NTEA



Remote control for the PT-LB60EA and PT-LB55EA

The remote control for the PT-LB60NTEA and PT-LB55NTEA features wireless projection controls including Microsoft® PowerPoint® page up/down capability.

The volume of the sound, from the built-in speaker or external speakers connected to the audio output terminal, can be adjusted using the remote control.



A total of three independent audio inputs are provided for PC 1, PC 2 and S-Video/Video.

Rear view

*1 As of February 7, 2006, according to our own evaluation of wireless transmission from PC to projector.

*2 PT-LB20NTEA.

*3 Content and DVDs set with DRM (Digital Rights Management) cannot be transmitted.

*4 For moving picture files in QVGA size.

*5 Transmission will be slower and certain functions are not available compared to when using a computer that has the software installed. Also, certain functions may not be available. (Please see operating instruction for details.)

*6 With Wireless Manager ME 3.0, you can use the projector screen as a secondary monitor for the PC. In this setup, Microsoft® PowerPoint® must be set to "Show Presenter View."

*7 Comparison with Daylight View 2 turned On and Off, using an 80-inch screen and ordinary meeting room lighting of 400 lux. (Projector: PT-LB60NTEA, screen gain: 2.6)

Specifications

Power supply	100–240 V AC, 50/60 Hz
Power consumption	300 W (Approx. 3 W in standby mode with fan stopped)
LCD panel	4:3 aspect ratio
Panel size	
PT-LB60NTEA/LB60EA	0.8" (20.32 mm) diagonal
PT-LB55NTEA/LB55EA	0.7" (17.78 mm) diagonal
Display method	Transparent LCD panel (x 3, R/G/B)
Drive method	Active matrix
Pixels	786,432 (1,024 x 768) x 3, total of 2,359,296 pixels
Pixel configuration	Stripe
Lens	Manual zoom (1:1–1.2), manual focus, F 1.7–1.8, f 24.0–28.8 mm
Lamp	220 W UHM™ lamp
Colours	Full colour (16,777,216 colours)
Brightness	
PT-LB60NTEA/LB60EA	3,200 lumens
PT-LB55NTEA/LB55EA	2,500 lumens
Contrast	400:1*1 (full on/full off)
Scanning frequency	
RGB	Horizontal: 15–91 kHz, Vertical: 50–85 Hz
YPbPr	480i (525i): fh 15.75 kHz; fv 60 Hz 576i (625i): fh 15.63 kHz; fv 50 Hz 480p (525p): fh 31.5 kHz; fv 60 Hz 576p (625p): fh 31.25 kHz; fv 50 Hz 720p (750p): fh 45 kHz; fv 60 Hz 1080i (1125i): fh 33.75 kHz; fv 60 Hz 1080i (1125i): fh 28.125 kHz; fv 50 Hz
S-Video/Video	NTSC, NTSC4.43, PAL-M, PAL60: fh 15.75 kHz; fv 60 Hz PAL, SECAM, PAL-N: fh 15.63 kHz; fv 50 Hz 33–300 inches/838–7,620 mm diagonally
Projection size	
Throw distance	
PT-LB60NTEA/LB60EA	1.1 m–10.8 m (3'7"–35'5")
PT-LB55NTEA/LB55EA	1.2 m–12.0 m (3'11"–39'4")
Optical axis shift	
PT-LB60NTEA/LB60EA	6:1 (fixed)
PT-LB55NTEA/LB55EA	9:1 (fixed)
Keystone correction range	Vertical: ±30°
On-screen menu	17 languages: English, French, German, Spanish, Italian, Korean, Russian, Chinese, Japanese, Swedish, Norwegian, Danish, Portuguese, Polish, Hungarian, Czech, and Thai
Installation	Front/rear ceiling/desk (menu selection)
Built-in speakers	4 x 3 cm x 1 (oval), 1.0 W (monaural) output power
Terminals	
PC 1 IN	D-sub HD 15-pin x 1
RGB signal	R, G, B: 0.7 Vp-p, 75 ohms, Sync on green: 1.0 Vp-p, 75 ohms HD/SYNC, VD: TTL (positive/negative polarity compatible)
YPbPr signal	Y: 1.0 Vp-p (including sync signal), 75 ohms; Pb, Pr: 0.7 Vp-p, 75 ohms
PC 2 IN/PC 1 OUT	D-sub HD 15-pin x 1 (input/output selectable using on-screen menu)
RGB signal	R, G, B: 0.7 Vp-p, 75 ohms, Sync on green: 1.0 Vp-p, 75 ohms HD/SYNC, VD: TTL (positive/negative polarity compatible)
YPbPr signal	Y: 1.0 Vp-p (including sync signal), 75 ohms; Pb, Pr: 0.7 Vp-p, 75 ohms

NOTES ON USE

- The projector uses a high-voltage mercury lamp that contains high internal pressure. This lamp may break, emitting a large sound, or fail to illuminate, due to impact or extended use. The length of time that it takes for the lamp to break or fail to illuminate varies greatly depending on individual lamp characteristics and usage conditions.
- The brightness of the lamp will gradually decrease with use.
- The lamp, LCD panel, polarising plate, and polarising beam splitter (PBS) are consumable parts. These parts may need to be replaced during the guarantee period if the projector is used for six or more hours per day.
- The replacement cycle of the LCD panel, polarising plate, and polarising beam splitter (PBS) will be shortened if the projector is subjected to continuous use for six or more hours. Likewise, the replacement cycle of the lamp will be shortened if the power is frequently turned on and off or the projector is subjected to continuous use for 10 or more hours.
- Interruptions may occur in the wireless connection due to signal interference or PC conditions.

VIDEO IN	RCA pin x 1, 1.0 Vp-p, 75 ohms
S-VIDEO IN	Mini DIN 4-pin x 1, Y: 1.0 Vp-p, C: 0.286 Vp-p, 75 ohms RCA (L-R) x 1, 0.5 Vrms (for VIDEO/S-VIDEO)
AUDIO IN	M3 (stereo) x 1, 0.5 Vrms
PC 1 AUDIO IN	M3 (stereo) x 1, 0.5 Vrms
PC 2 AUDIO IN	M3 (stereo) x 1, 0–2.0 Vrms (variable)
AUDIO OUT	Mini DIN 8-pin x 1 (RS-232C)
SERIAL	2 m (6'7")
Power cord length	Moulded material (ABS/PC)
Cabinet material	327 x 83 x 233 mm (12-27/32" x 3-1/4" x 9-5/32")
Dimensions*2 (W x H x D)	
Weight	
PT-LB60NTEA/LB55NTEA	2.6 kg (5.7 lbs.)
PT-LB60EA/LB55EA	2.5 kg (5.5 lbs.)
Operating environment	
Temperature	0°–40°C (32°–104°F)
Humidity	20%–80% (no condensation)
Remote Control Unit	
Power supply	3 V DC (AAA battery x 2)
Operation range*3	Approx. 7 m (23 feet) when operated from directly in front of the signal receptor
Dimensions (W x H x D)	51.5 x 123 x 2.11 mm (2" x 4-13/16" x 13/16") 74 g (2.6 ozs.) (including batteries)
Weight	
Wireless LAN (PT-LB60NTEA/LB55NTEA)	
Standard Modulation	IEEE802.11b/g
IEEE802.11b	Direct sequence spread spectrum (ds-ss) system
IEEE802.11g	Orthogonal frequency division multiplex (OFDM) system
Transmission system	
IEEE802.11b	CCK (11/5.5 Mbps), DOPSK (2 Mbps), DBPSK (1 Mbps)
IEEE802.11g	64-QAM (54/48 Mbps), 16-QAM (36/24 Mbps), QPSK (18/12 Mbps), BPSK (9/6 Mbps)
Transmission speed	
IEEE 802.11b	11 Mbps, 5.5 Mbps, 2 Mbps, 1 Mbps
IEEE 802.11g	54 Mbps, 48 Mbps, 36 Mbps, 24 Mbps, 18 Mbps, 12 Mbps, 9 Mbps, 6 Mbps
Operation range*3	Approx. 30 m (98'5")
Frequency range	2,412 MHz–2,472 MHz
Channels	1–13 ch
Supplied Accessories	<ul style="list-style-type: none"> Power cord Wireless remote control Batteries for remote control VGA cable Lens cover Carrying bag Wireless Manager ME 3.0 (CD-ROM)**4
Optional Accessories	<ul style="list-style-type: none"> ET-LAB30 Replacement lamp unit ET-PKB30 Ceiling mount bracket ET-RM300 Full-function wireless remote control ET-ADSER Serial adapter (DIN 8-pin/D-sub 9-pin)

*1: In AI mode.

*2: Legs and protruding parts not included.

*3: Operation range differs depending on the environment.

*4: For the PT-LB60NTEA and PT-LB55NTEA only.

Dimensions

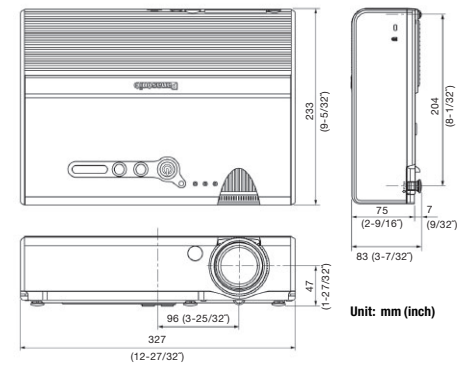

Projection Distance

PT-LB60NTEA/LB60EA

Diagonal image size (4:3 aspect ratio)	Distance to screen (L)			Height from the edge of screen to center of lens
	min.	recommended*	max.	
33" / 0.84 m / 2.7'	—	—	1.1 m / 3.6'	5 cm / 2.0"
40" / 1.02 m / 3.3'	1.2 m / 3.9'	1.4 m / 4.6'	1.4 m / 4.6'	8 cm / 3.1"
50" / 1.27 m / 4.2'	1.5 m / 4.9'	1.7 m / 5.6'	1.7 m / 5.6'	11 cm / 4.3"
60" / 1.52 m / 4.9'	1.8 m / 5.9'	2.1 m / 6.9'	2.1 m / 6.9'	13 cm / 5.1"
70" / 1.78 m / 5.8'	2.1 m / 6.9'	2.5 m / 8.5'	2.5 m / 8.5'	15 cm / 6.3"
80" / 2.03 m / 6.7'	2.4 m / 7.9'	2.8 m / 9.2'	2.8 m / 9.2'	17 cm / 6.7"
90" / 2.29 m / 7.5'	2.7 m / 8.9'	3.2 m / 10.5'	3.2 m / 10.5'	19 cm / 7.5"
100" / 2.54 m / 8.3'	3.0 m / 9.8'	3.5 m / 11.5'	3.5 m / 11.5'	21 cm / 8.3"
120" / 3.05 m / 10.0'	3.6 m / 11.8'	4.3 m / 14.1'	4.3 m / 14.1'	25 cm / 9.8"
150" / 3.81 m / 12.5'	4.6 m / 15.1'	5.4 m / 17.7'	5.4 m / 17.7'	32 cm / 12.6"
200" / 5.08 m / 16.7'	6.1 m / 20.0'	7.2 m / 23.6'	7.2 m / 23.6'	42 cm / 16.5"
250" / 6.35 m / 20.8'	7.6 m / 24.9'	9.0 m / 29.5'	9.0 m / 29.5'	53 cm / 20.9"
300" / 7.62 m / 25.0'	9.1 m / 29.9'	10.8 m / 35.4'	10.8 m / 35.4'	63 cm / 24.8"

PT-LB55NTEA/LB55EA

Diagonal image size (4:3 aspect ratio)	Distance to screen (L)			Height from the edge of screen to center of lens
	min.	recommended*	max.	
33" / 0.84 m / 2.7'	—	—	1.2 m / 3.9'	5 cm / 2.0"
40" / 1.02 m / 3.3'	1.4 m / 4.6'	1.5 m / 4.9'	1.5 m / 4.9'	6 cm / 2.4"
50" / 1.27 m / 4.2'	1.7 m / 5.6'	1.9 m / 6.2'	1.9 m / 6.2'	7 cm / 2.8"
60" / 1.52 m / 4.9'	2.0 m / 6.6'	2.3 m / 7.5'	2.3 m / 7.5'	9 cm / 3.5"
70" / 1.78 m / 5.8'	2.4 m / 7.9'	2.7 m / 8.9'	2.7 m / 8.9'	10 cm / 3.9"
80" / 2.03 m / 6.7'	2.7 m / 8.9'	3.1 m / 10.2'	3.1 m / 10.2'	12 cm / 4.7"
90" / 2.29 m / 7.5'	3.0 m / 9.8'	3.5 m / 11.5'	3.5 m / 11.5'	13 cm / 5.1"
100" / 2.54 m / 8.3'	3.4 m / 11.2'	4.0 m / 13.1'	4.0 m / 13.1'	15 cm / 5.9"
120" / 3.05 m / 10.0'	4.1 m / 13.5'	4.8 m / 15.7'	4.8 m / 15.7'	18 cm / 7.1"
150" / 3.81 m / 12.5'	5.1 m / 16.7'	6.0 m / 19.7'	6.0 m / 19.7'	22 cm / 8.7"
200" / 5.08 m / 16.7'	6.8 m / 22.3'	8.0 m / 26.2'	8.0 m / 26.2'	30 cm / 11.8"
250" / 6.35 m / 20.8'	8.4 m / 27.6'	10.0 m / 32.8'	10.0 m / 32.8'	37 cm / 14.6"
300" / 7.62 m / 25.0'	10.1 m / 33.1'	12.0 m / 39.4'	12.0 m / 39.4'	44 cm / 17.3"



Optional replacement lamp unit: ET-LAB30

Ecology-Conscious Design

Panasonic works from every angle to minimise environmental impact in the product design, production and delivery processes, and in the performance of the product itself over its life cycle. The PT-LB60/LB55 series models reflect the following ecological considerations.

- Lead-free solder is used to mount components to the printed circuit boards.
- No halogenated flame retardants are used in the cabinet.
- No styrofoam is used in the packing materials.
- Lead-free glass is used for the lens.
- The packing case and operating manual are made from recycled paper.

Panasonic

Weights and dimensions shown are approximate. Specifications are subject to change without notice. Product availability differs depending on region and country. This product may be subject to export control regulations. UHM is a trademark of Matsushita Electric Industrial Co., Ltd. VGA and XGA are trademarks of International Business Machines Corporation. Windows and PowerPoint are either registered trademarks or trademarks of Microsoft Corporation in the United States and/or other countries. All other trademarks are the property of their respective trademark owners. Projection images simulated.